



SCHEEPSHELLING VLISSINGEN

ANALYSE

APRIL 2021

RANDVOORWAARDEN

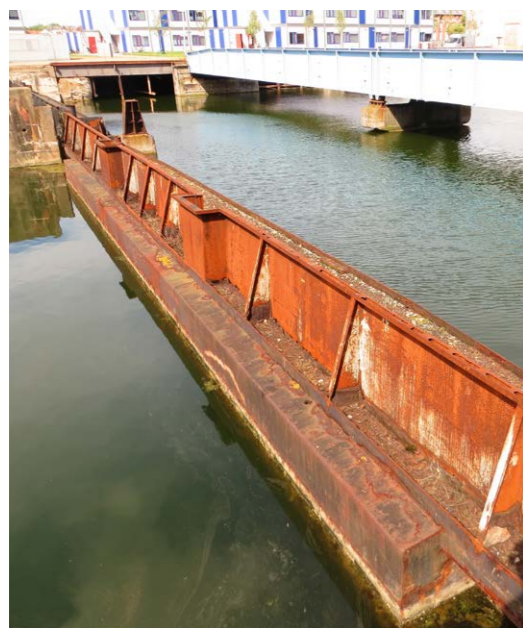

Verkeer en parkeren

- Verbinding tussen binnenstad en De Willem Ruysstraat
- Faciliteren van laden en lossen (zwaar verkeer).

Materialisatie

- Betonelementen.
- Groen.
- Speciale objecten in cortenstaal uitvoeren.
- Hergebruik objecten/materialen.

Bijzondere objecten en accenten

- Zoveel mogelijk maritieme elementen op de kade behouden, zoals de monumentale Scheldekraan en oude spoor- en kraanbanen en kleinere elementen zoals bolders.
- Combineren met nieuwe inrichtingselementen

Uitgangspunten

- De Helling wordt opgevuld i.v.m. staat beton.
- Inpassen kunstwerk 'Mannen tussen staal'

Overige

- Inpassen tracés kabels en leidingen.
- De inrichting van het gehele plangebied is toegankelijk voor mindervaliden.

HISTORIE

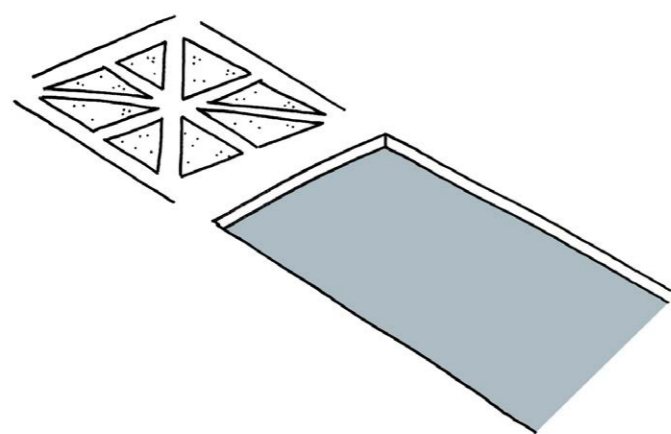
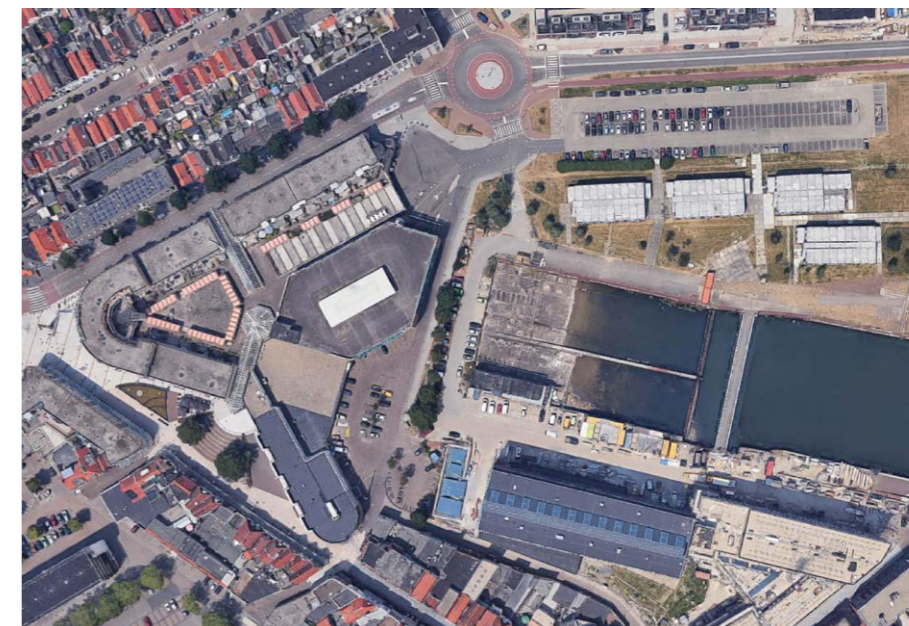
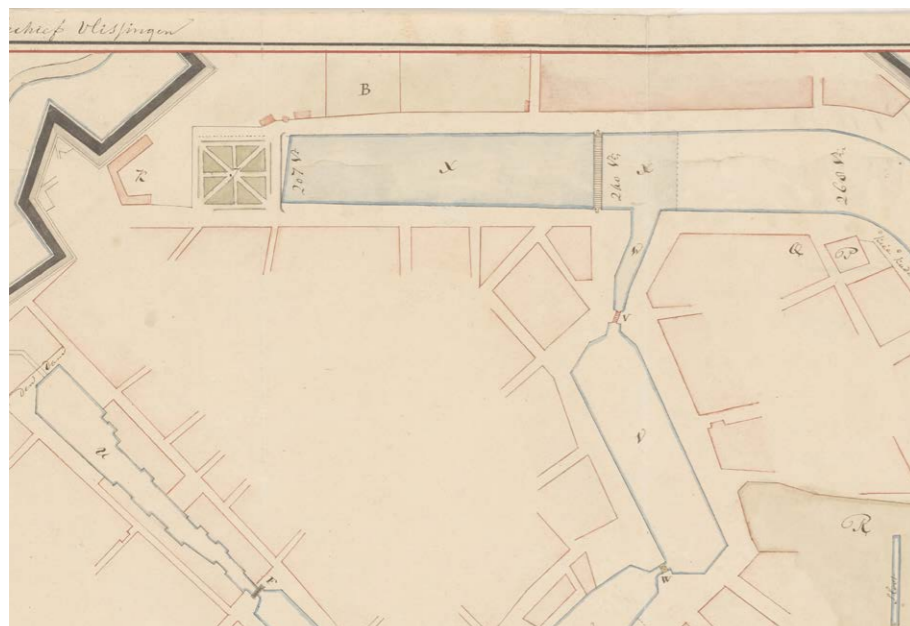

1783 - Park aan het dok

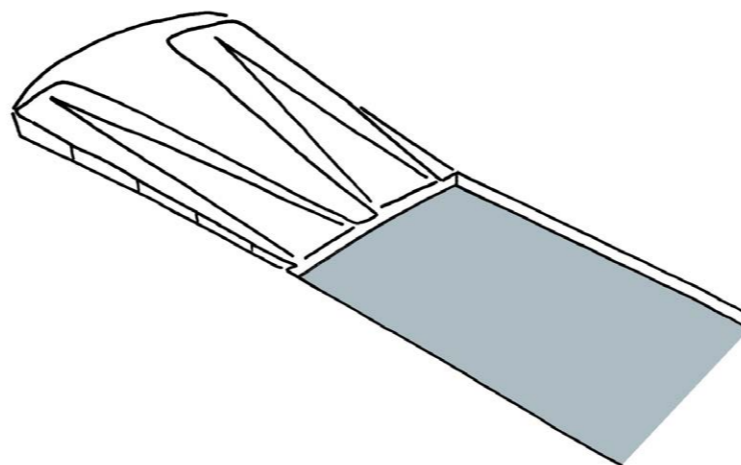

1867 - De Helling

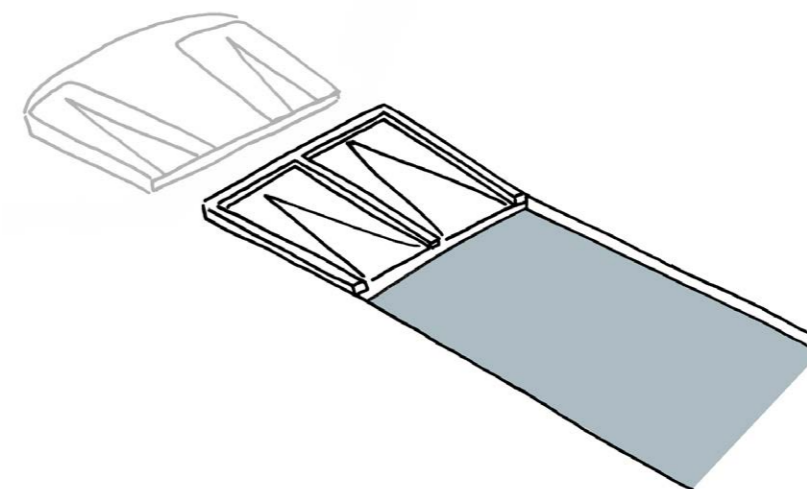

Heden - Relict

SCHAAL VAN DE PLEK

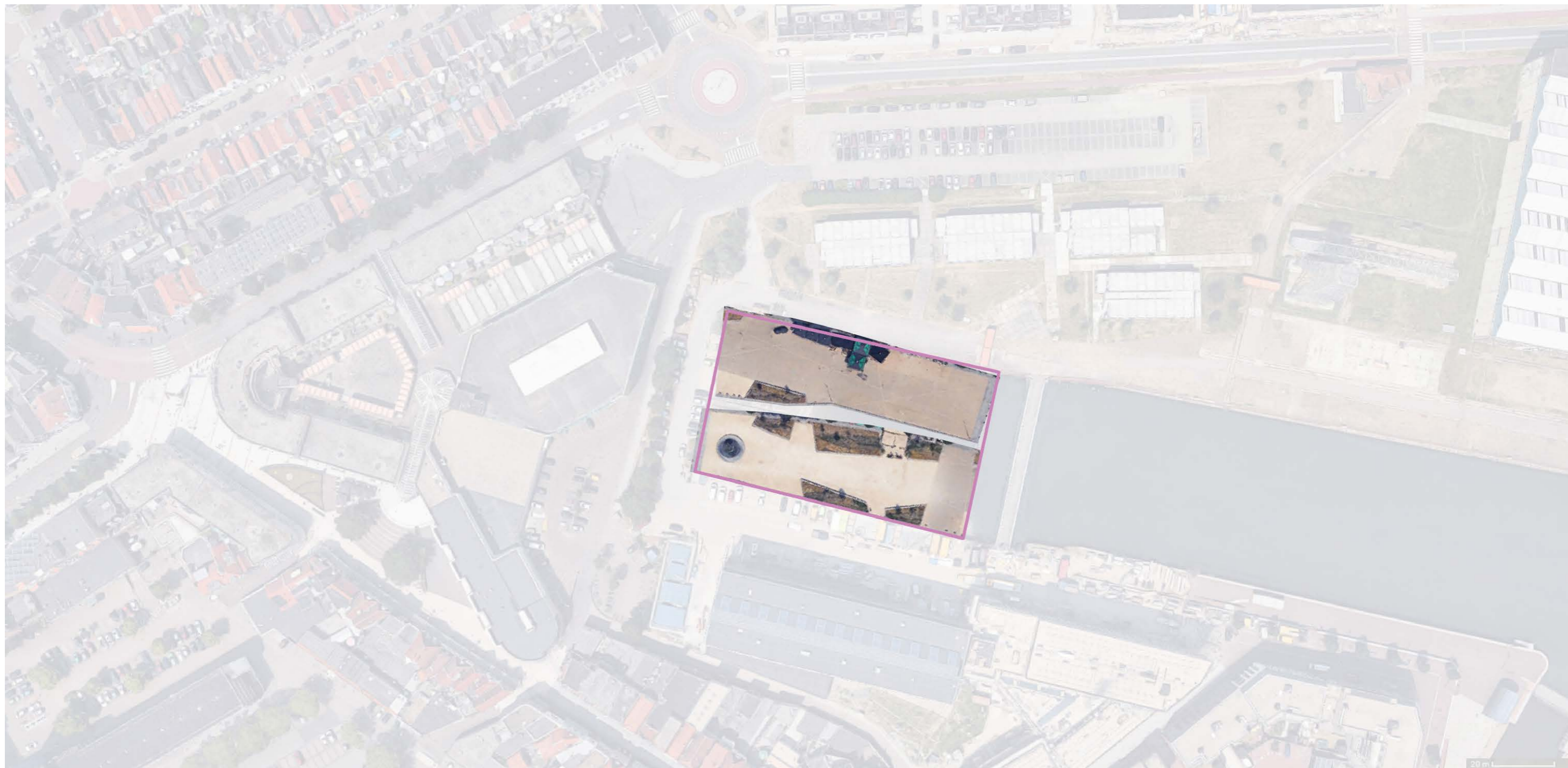

Bellamypark

SCHAAL VAN DE PLEK

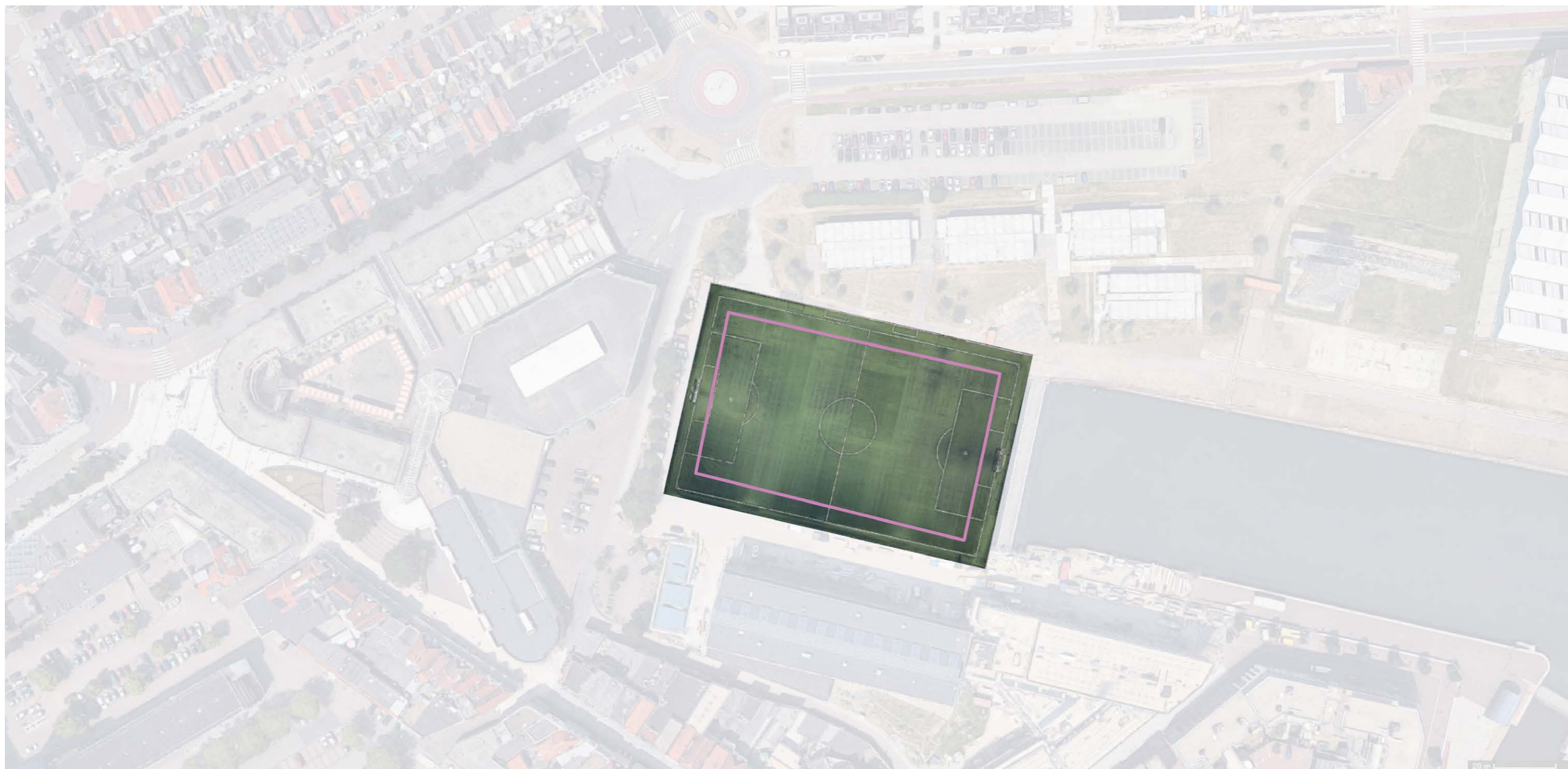

Voetbalveld

ONTWIKKELINGEN

- Langzaamverkeersverbinding
- Rijloper richting Zwaarplaatwerkerij
- Wonen / Zorg rondom de Helling
- Kade- & deksloofherstel
- Verplaatsen 'Mannen tussen Staal'
- Hergebruik Blauwe brug

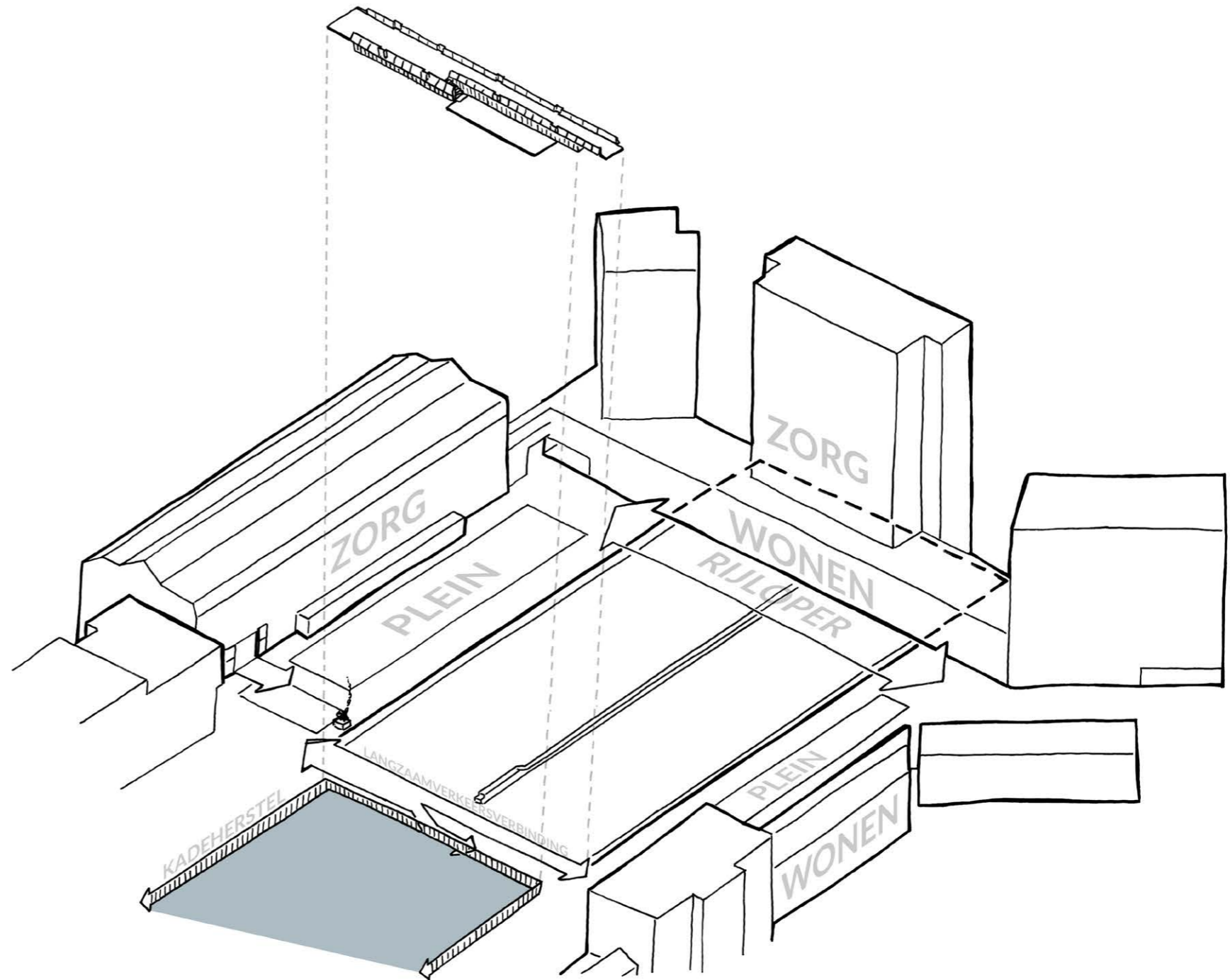

RANDVOORWAARDEN

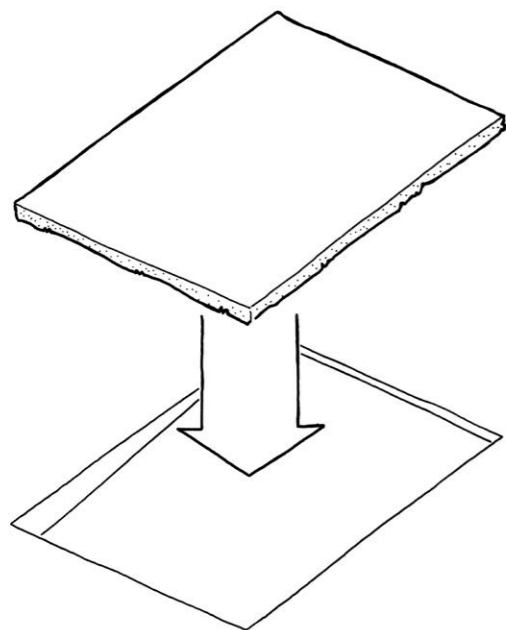

Opvullen

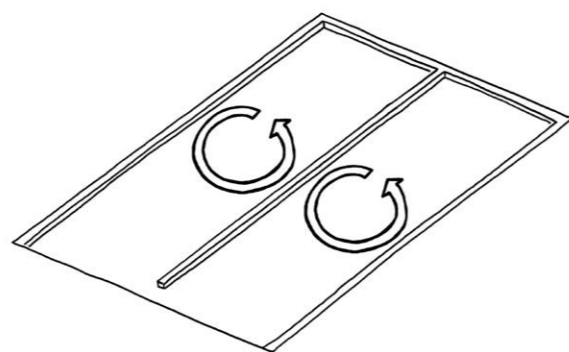

Relicten van de helling

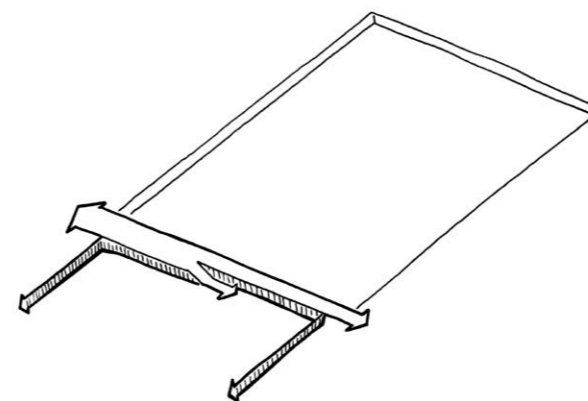

Verbinding / Waterkering

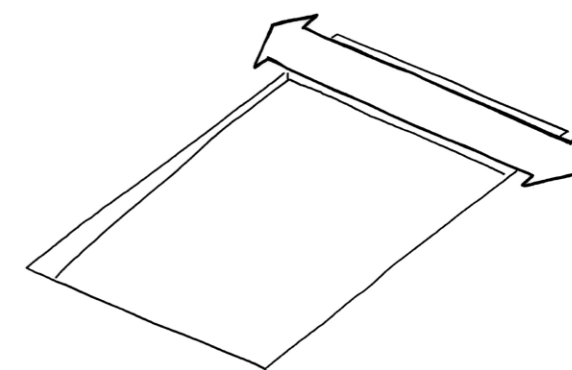

Rijloper

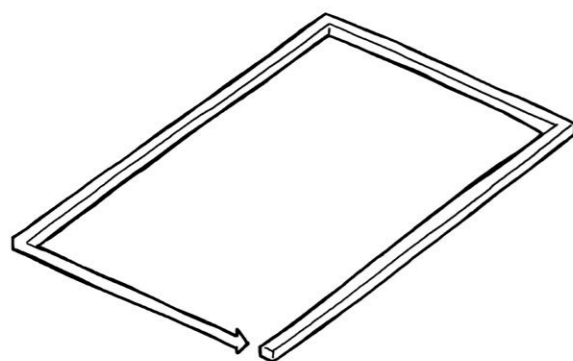

Heldere rand

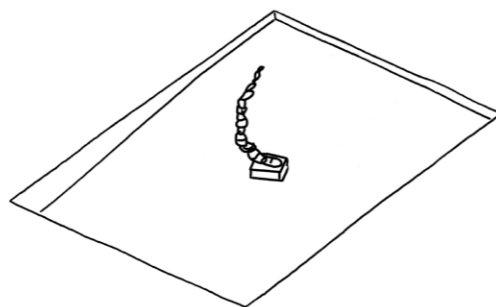

Inpassing Mannen tussen Staal

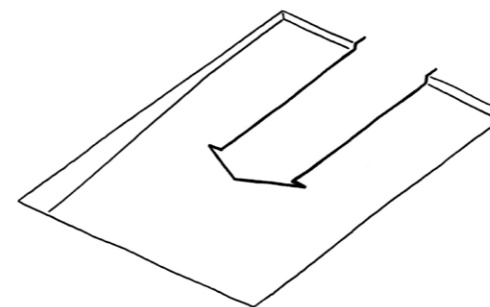

Toegankelijkheid

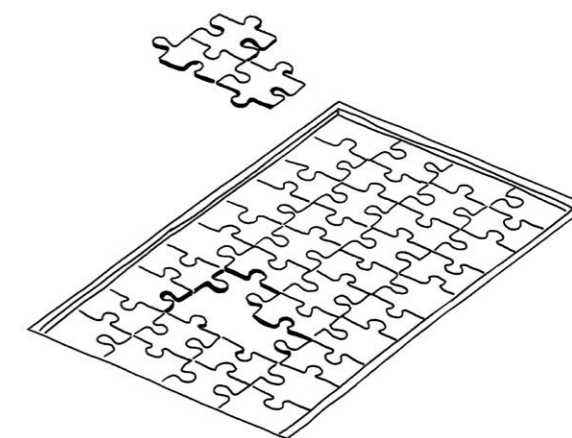

Flexibel gebruik

INSPIRATIE

